

BF TYPE SEWAGE PUMP

FEATURES

- Best quality meet international standard.
- Light weight, compact and strong structure elegant shape and easy operation.
- Dry motor without cooling oil. Equipped with auto-cut to protect motor from burning.
- Double mechanical seal plus oil seal and shaft sleeve design, totally water proof to prolong pump operation life.
- Optional material for shaft, M seal, and impeller.

APPLICATIONS

- Drainage of waste water from the liberating tank, purifying tank and sewage tank in water treatment plant.
- Drainage of sewage from the basement of buildings, hotel industry, waste water from factory, and waste water from food processing industry.
- Sewage management, accumulated water, septic tank, stock farm.



PERFORMANCE CURVE

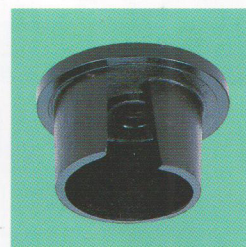
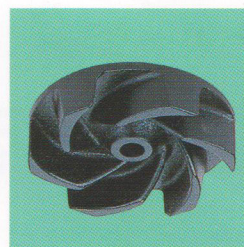
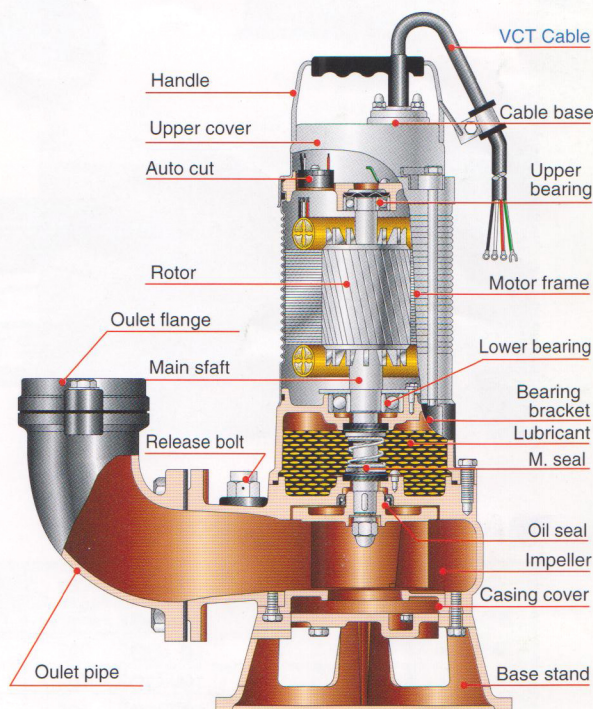
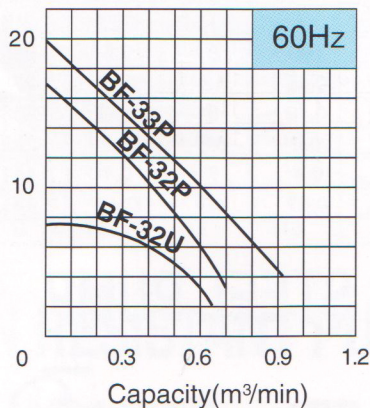
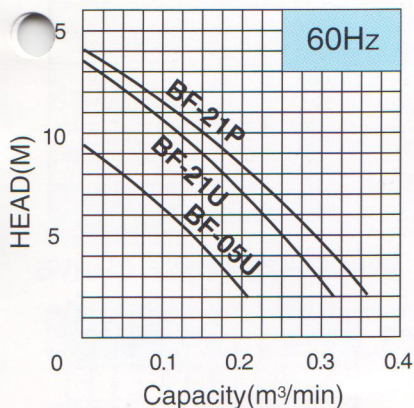
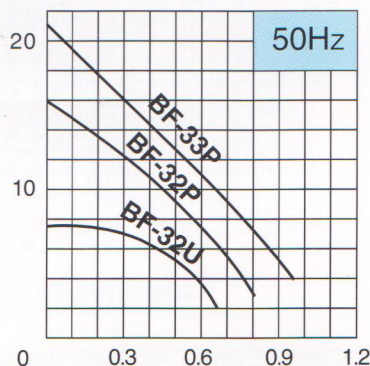
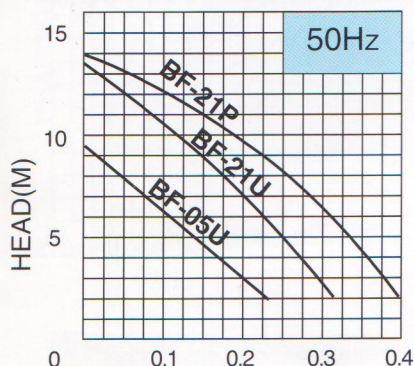

● U type impeller

● P type impeller

PERFORMANCE SPEC.

Type	HP	Discharge (Inch)	Phase	P	50Hz Head (M)	50Hz Capacity (m ³ /min)	60Hz Head (M)	60Hz Capacity (m ³ /min)	Length (mm)	Width (mm)	Height (mm)	Weight (kg)	Solid passage (mm)
BF-05U	1/2	2	10 · 30	2	6	0.12	6	0.12	228	153	410	15	35
BF-21P	1	2	10 · 30	2	9	0.22	8	0.22	274	235	448	20	17
BF-21U	1	2	10 · 30	2	7	0.2	7	0.2	228	153	410	16	35
BF-32P	2	3	10 · 30	2	9	0.52	8	0.52	418	250	549	38	30
BF-32U	2	3	10 · 30	2	5	0.55	5	0.5	418	250	549	38	46
BF-33P	3	3	30	2	11	0.6	10	0.6	418	250	575	40	32

1/2N 1 HP single phase available with float switch.