

# TOP MULTI®

## Submersible multi-impeller pumps



### PERFORMANCE RANGE

- Flow rate up to **120 l/min** (7.2 m<sup>3</sup>/h)
- Head up to **42 m**

### APPLICATION LIMITS

- Immersion depth:
  - **5 m** with 10 m long power cable
  - **10 m** with a sufficiently long power cable
- Maximum liquid temperature **+40 °C**
- Passage of suspended solids up to **Ø 1.3 mm**
- Suction down to **22 mm** above ground level
- Continuous service **S1**

### CONSTRUCTION AND SAFETY STANDARDS

Complete with:  
– **10 m** long power cable  
– float switch

EN 60335-1  
IEC 60335-1  
CEI 61-150

EN 60034-1  
IEC 60034-1  
CEI 2-3



### INSTALLATION AND USE

Suitable for use with clean water and liquids that are not chemically aggressive towards the materials from which the pump is made. As a result of their high efficiency and reliability they are suitable for use in applications such as domestic water supply from reservoirs, tanks or relatively deep wells, for drawing rain water from cisterns to water gardens or for use in irrigation systems, etc.

### PATENTS - TRADE MARKS - MODELS

- Registered model TOP MULTI® n° 1334477
- Registered Community Design n° 000885587

### OPTIONALS AVAILABLE ON REQUEST

- Pumps without float switch
- Other voltages or 60 Hz frequency

### GUARANTEE

2 years subject to terms and conditions

### CERTIFICATIONS



**CHARACTERISTIC CURVES AND PERFORMANCE DATA**

**50 Hz n= 2900 1/min**

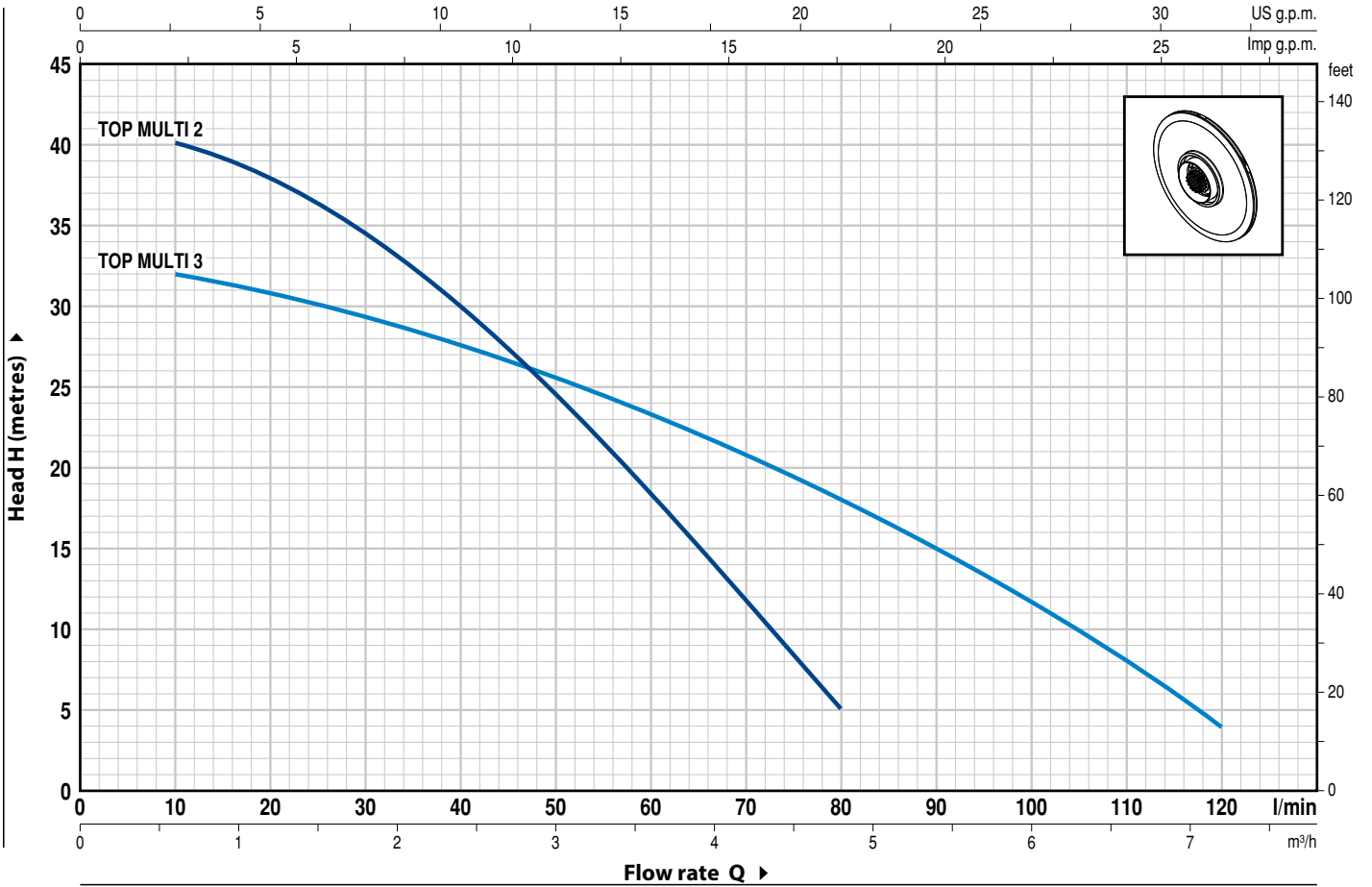

MODEL	POWER		Q	Flow rate															
	kW	HP		0	0.6	1.2	1.8	2.4	3.0	3.6	4.2	4.8	5.4	6.0	6.6	7.2			
Single-phase				0	10	20	30	40	50	60	70	80	90	100	110	120			
<b>TOP MULTI 2</b>	0.55	0.75	H metres	42	40	38	34	30	24	18	11.5	5							
<b>TOP MULTI 3</b>	0.55	0.75	H metres	33	32	31	29.5	28	25.5	23	20.5	18	15	12	8	4			

Q = Flow rate H = Total manometric head

Tolerance of characteristic curves in compliance with EN ISO 9906 Grade 3.

POS.	COMPONENT	CONSTRUCTION CHARACTERISTICS				
1	<b>DELIVERY BODY</b>	Glass fibre reinforced technopolymer, complete with threaded delivery port in compliance with ISO 228/1				
2	<b>PUMP BODY AND SUCTION FILTER</b>	Glass fibre reinforced technopolymer				
3	<b>MOTOR SLEEVE</b>	Stainless steel AISI 304				
4	<b>IMPELLERS</b>	Noryl GFN2V				
5	<b>DIFFUSERS</b>	Noryl GFN2V complete with anti-wear rings				
6	<b>MOTOR SHAFT</b>	Stainless steel EN 10088-3 - 1.4104				
7	<b>TWO MECHANICAL SEALS SEPARATED BY AN OIL CHAMBER</b>					
	<i>Seal</i>	<i>Shaft</i>	<i>Position</i>	<i>Materials</i>		
	<i>Model</i>	<i>Diameter</i>		<i>Stationary ring</i>	<i>Rotational ring</i>	<i>Elastomer</i>
	STA-13R	Ø 13 mm	Motor side	Ceramic	Graphite	NBR
	STA-12R SIC	Ø 12 mm	Pump side	Ceramic	Silicon carbide	NBR
8	<b>BEARINGS</b>	<b>6202 ZZ - C3 / 6201 ZZ</b>				
9	<b>CAPACITOR</b>					
	<b>Capacitance</b>					
	(230 V or 240 V)	(110 V)				
	12.5 µF 450 VL	30 µF 250 VL				
10	<b>ELECTRIC MOTOR</b>					
	<b>TOP MULTI:</b> single-phase 230 V - 50 Hz with built-in overload protector.					
	- Insulation: F class.					
	- Protection: IP X8.					
11	<b>POWER CABLE</b>					
	⇒ 10 metre long "H07 RN-F" cable with Schuko plug					
12	<b>FLOAT SWITCH</b>					
13	<b>HOSE CONNECTOR WITH UNION</b>					
	Ø 35 mm hose connection					
14	<b>PIPE COUPLING</b>					
	Threaded 1¼" in compliance with ISO 228/1, complete with clapet valve					

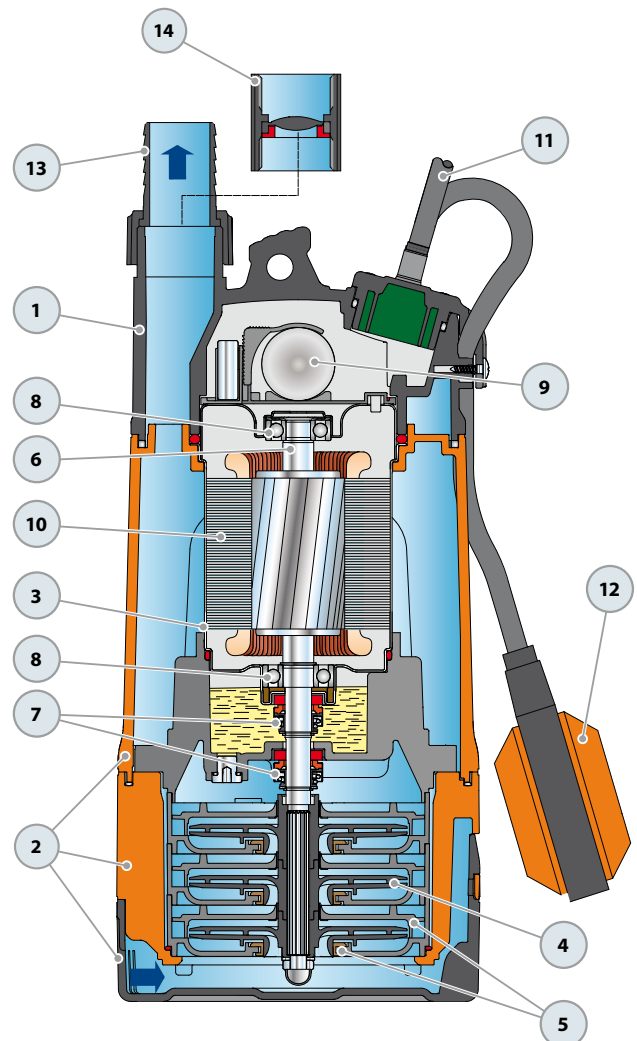

## DIMENSIONS AND WEIGHT

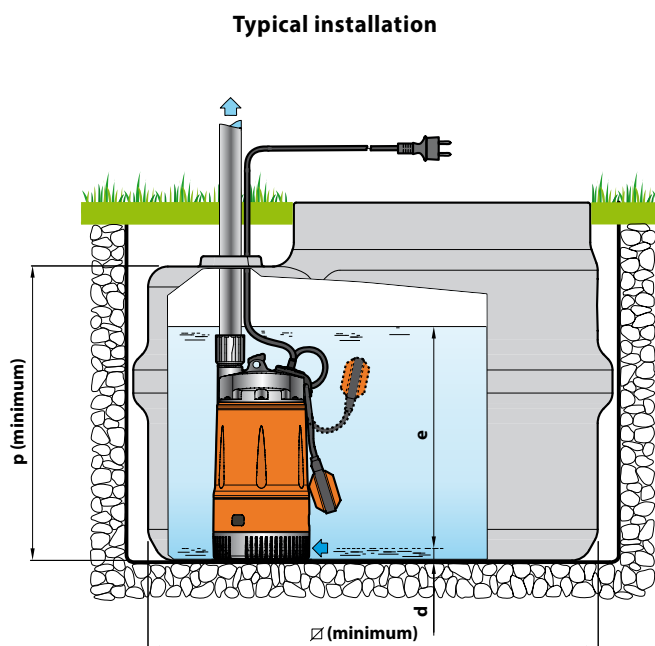
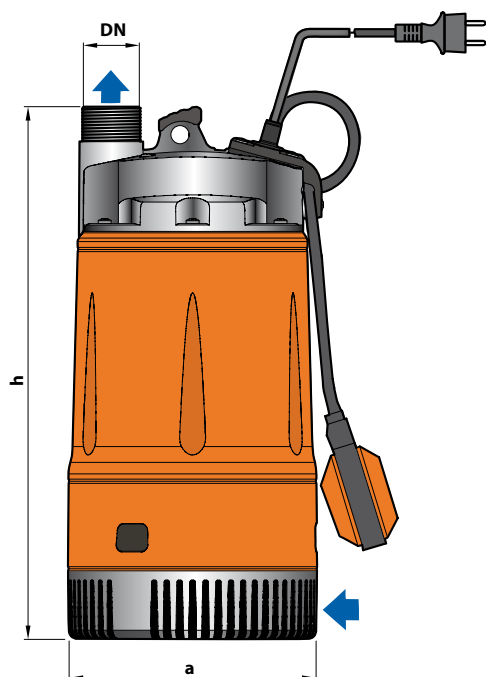

MODEL	PORT DN	N° STAGES	DIMENSIONS mm						kg
			a	h	d	e	p	Ø	
Single-phase	1¼"	3	178	380	22	variable	500	500	9.4
TOP MULTI 2									
TOP MULTI 3									

## ABSORPTION

MODEL	VOLTAGE (single-phase)		
	230 V	240 V	110 V
TOP MULTI 2	3.4 A	3.3 A	6.8 A
TOP MULTI 3	3.6 A	3.5 A	7.2 A

## PALLETIZATION

MODEL	GROUPAGE			CONTAINER		
	n° pumps	H (mm)	kg	n° pumps	H (mm)	kg
TOP MULTI 2	60	1370	582	80	1780	770
TOP MULTI 3	60	1370	582	80	1780	770

